



Touchpad Caddy Assembly Instructions

Thank you for purchasing a touchpad caddy to protect and store your Colorado Time Systems' touchpads. Your caddy was shipped partially assembled. Please follow these instructions to complete the assembly.

Parts: You should have received all the parts shown in Figure 2 located on the back page. If you are missing any parts or have questions, please call our customer service department at 800-287-0653, x256.

Tool Required: 9/16" wrench

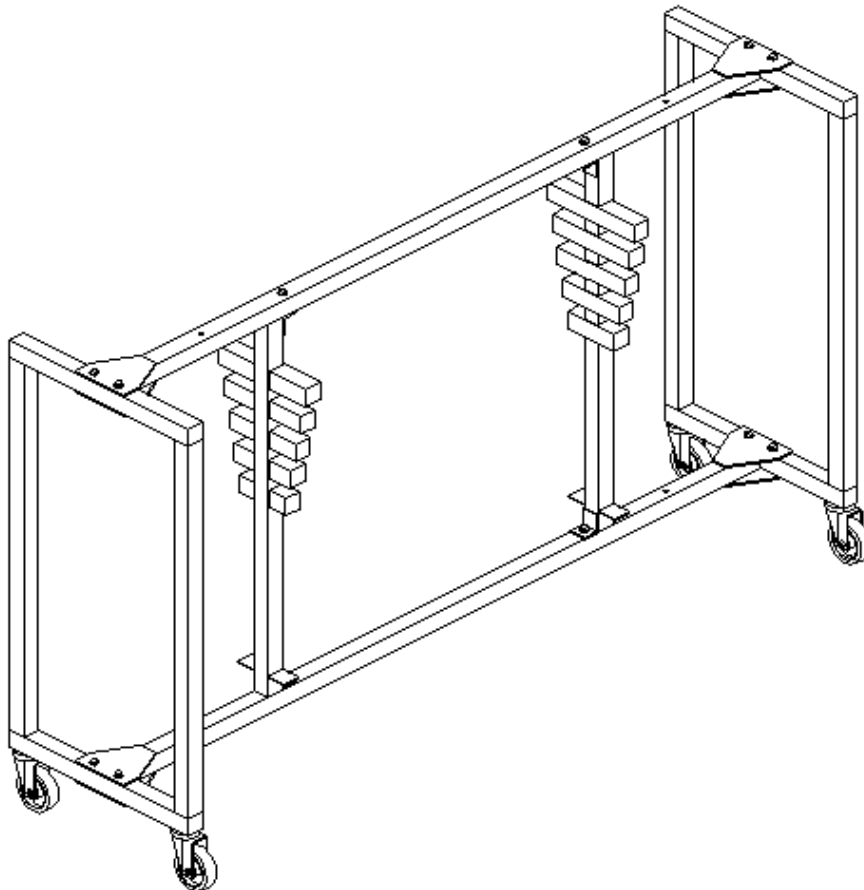

Figure 1 - Assembled Touchpad Caddy

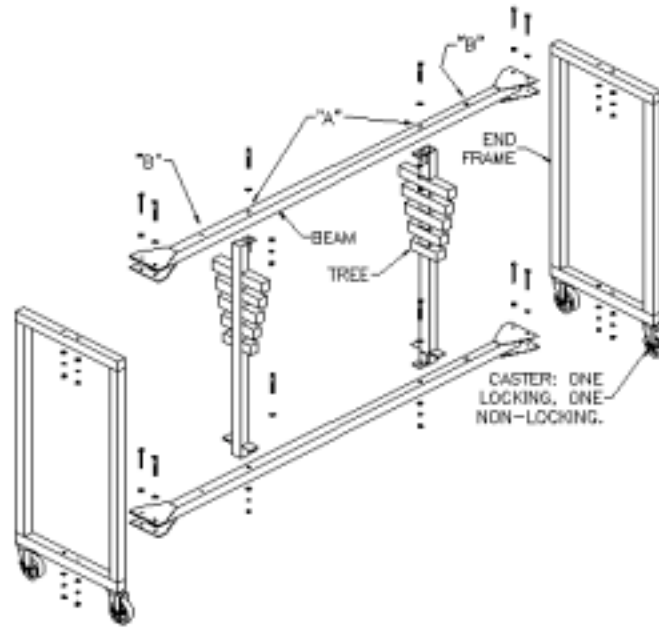

Figure 2 - Touchpad Caddy: separated parts

1. Bolt the cross beams to the end frames as shown in Figure 3.
2. Mount the touchpad support trees between the top and bottom beams and bolt in place. For 60" touchpads (model TP60G) use holes labeled "A." For 78" touchpads (model TP78G) use holes labeled "B."
3. The caddy is finished and ready to accept touchpads.

When loading the touchpads, always start at the lowest support on the support tree. The Velcro® hook on the touchpad supports must catch the Velcro® loop on the underside of the touchpad lip. Place the touchpad as far back (toward the center of the caddy frame) as you can on the support. Place the next touchpad on the lowest support on the other side. Place the next pair of touchpads on the next higher level supports, and continue loading the caddy in this manner.

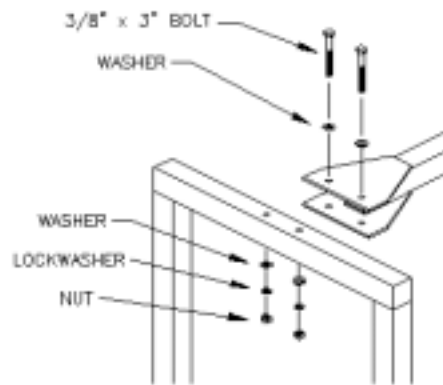

Figure 3 - Cross Beam Assembly

Note: Each touchpad is an expensive electronic sensor that must be handled carefully. When touchpads are loaded on the caddy, do not place the caddy in direct sunlight or near a heat source. The touchpads are constructed of PVC plastic and may become deformed if subjected to direct sunlight or heat.

Colorado Time Systems
 1551 East 11th Street, Loveland, CO 80537
 Phone: 970-667-1000 ext. 256 Fax: 970-667-1032
 Toll Free: 800-287-0653 ext. 256 www.coloradotime.com